

METALMASTER

OPERATION MANUAL

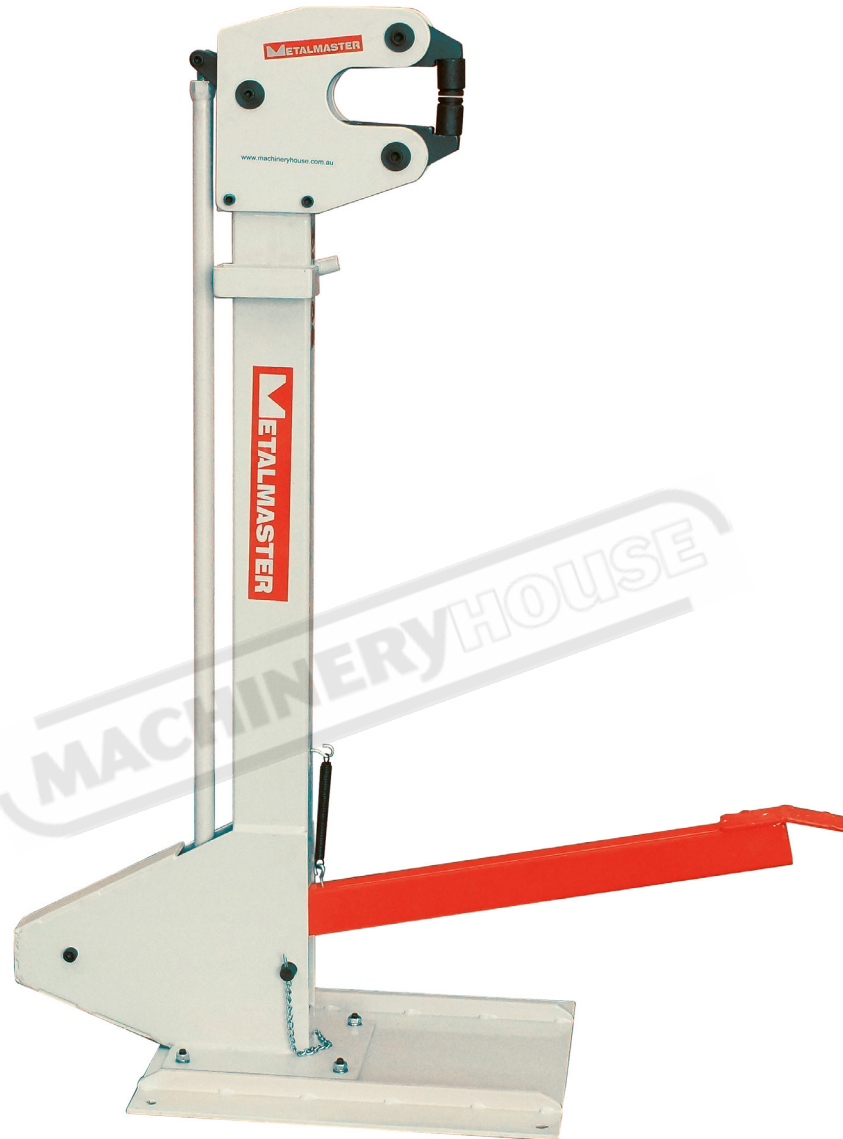

Shrinker Stretcher

Model. SHST1.2HO

Order Code S2264

Edition No : SHST1.2HO-1

Date of Issue : 02/2021

www.machineryhouse.com.au

MACHINE DETAILS**MACHINE**

SHRINKER STRETCHER

MODEL NO.

SHST1.2HO

SERIAL NO.**DATE OF MANF.**

Distributed by

MACHINERYHOUSEwww.machineryhouse.com.auwww.machineryhouse.co.nz**Note:**

This manual is only for your reference. Owing to the continuous improvement of the Metalmaster machine, changes may be made at any time without obligation or notice. Please ensure the local voltage is the same as listed on the specification plate before operating any electric machine.

**NOTE:**

In order to see the type and model of the machine, please see the specification plate. Usually found on the back of the machine. See example (Fig.1)

METALMASTER
PRODUCT SPECIFICATION

MODEL:

SER NO:

MFG DATE:

CAPACITY:

www.machineryhouse.com.au
Made in China

Fig.1

CONTENTS:

1. GENERAL MACHINE INFORMATION	
1.1 Specifications.....	4
1.2 Accessories Included.....	4
1.3 Identification.....	5
2. IMPORTANT INFORMATION	
2.1 General Metalworking Machine Safety.....	6
2.2 Specific Safety For Shrinker Stretchers.....	9
2.3 Lifting Instructions.....	10
3. SETUP	
3.1 Assembly.....	11
3.2 Clean Up.....	12
3.3 Site Preparation.....	12
3.4 Machine Leveling.....	12
4. OPERATION	
4.1 Operation Overview.....	13
5. MAINTENANCE	
5.1 Cleaning And Oiling.....	14
Spare Parts.....	15
Risk Assessment Sheets.....	18

1.1 SPECIFICATION

Order Code	S2264
MODEL	SHST1.2HO
Operation (Type)	Foot Operated
Mild Steel - Capacity (mm/gauge)	1.2 / 18
Aluminium - Capacity (mm/gauge)	1.8 / 15
Throat Depth (mm)	130
Working Height (mm)	1050
Dimensions (L x W x H) (mm)	512 x 480 x 1160
Packing Dimensions (L x W x H) (mm)	1160 x 480 x 190
Weight (kg)	30

MACHINERYHOUSE

1.2 ACCESSORIES INCLUDED

1 Set CR12 Steel Shrinker Jaws
1 Set CR12 Steel Stretcher jaws
Metal Stand
Instruction Manual

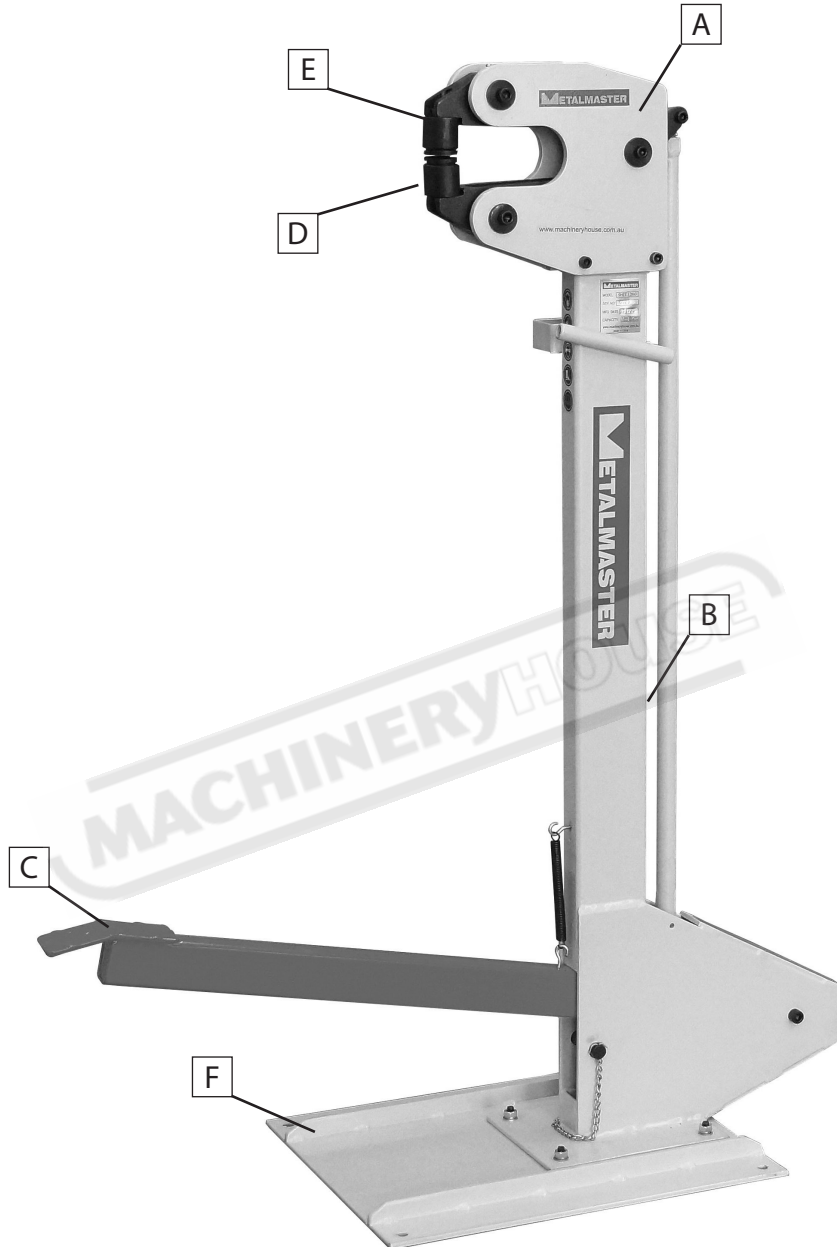
1.3 IDENTIFICATION

A	Head	D	Bottom Jaw
B	Stand	E	Top Jaw
C	Foot Pedal	F	Base

2.1 GENERAL METALWORKING MACHINE SAFETY

DO NOT use this machine unless you have read this manual or have been instructed in the use of this machine in its safe use and operation



WARNING

This manual provides safety instructions on the proper setup, operation, maintenance, and service of this machine. Save this manual, refer to it often, and use it to instruct other operators. Failure to read, understand and follow the instructions in this manual may result in fire or serious personal injury—including amputation, electrocution, or death.

The owner of this machine is solely responsible for its safe use. This responsibility includes, but is not limited to proper installation in a safe environment, personnel training and authorization to use, proper inspection and maintenance, manual availability and comprehension, of the application of the safety devices, integrity, and the use of personal protective equipment.

The manufacturer will not be held liable for injury or property damage from negligence, improper training, machine modifications or misuse.



- ✓ Always wear safety glasses or goggles.
- ✓ Wear appropriate safety footwear.
- ✓ Wear respiratory protection where required.
- ✓ Gloves should never be worn while operating an electric machine, and only worn when handling the work-piece.
- ✓ Wear hearing protection in areas > 85 dBA. If you have trouble hearing someone speak from one metre (three feet) away, the noise level from the machine may be hazardous.
- ✓ DISCONNECTION THE MACHINE FROM POWER when making adjustments or servicing.
- ✓ Check and adjust all safety devices before each job.
- ✓ Ensure that guards are in position and in good working condition before operating.
- ✓ Ensure that all stationary equipment is anchored securely to the floor.
- ✓ Ensure all machines have a start/stop button within easy reach of the operator.
- ✓ Each machine should have only one operator at a time. However, everyone should know how to stop the machine in an emergency.

2.1 GENERAL METALWORKING MACHINE SAFETY Cont.

- ✓ Ensure that keys and adjusting wrenches have been removed from the machine before turning on the power. Appropriate storage for tooling should be provided.
- ✓ Ensure that all cutting tools and blades are clean and sharp. They should be able to cut freely without being forced.
- ✓ Stop the machine before measuring, cleaning or making any adjustments.
- ✓ Wait until the machine has stopped running to clear cuttings with a vacuum, brush or rake.
- ✓ Keep hands away from the cutting head and all moving parts.
- ✓ Avoid awkward operations and hand positions. A sudden slip could cause the hand to move into the cutting tool or blade.
- ✓ Return all portable tooling to their proper storage place after use.
- ✓ Clean all tools after use.
- ✓ Keep work area clean. Floors should be level and have a non-slip surface.
- ✓ Use good lighting so that the work piece, cutting blades, and machine controls can be seen clearly. Position any shade lighting sources so that they do not cause any glare or reflections.
- ✓ Ensure there is enough room around the machine to do the job safely.
- ✓ Obtain first aid immediately for all injuries.
- ✓ Understand that the health and fire hazards can vary from material to material. Make sure all appropriate precautions are taken.
- ✓ Clean machines and the surrounding area when the operation is finished.
- ✓ Use proper lock out procedures when servicing or cleaning the machines or power tools.

DO NOT

- × Do not distract an operator. Horseplay can lead to injuries and should be strictly prohibited.
- × Do not wear loose clothing, gloves, necktie's, rings, bracelets or other jewellery that can be come entangled in moving parts. Confine long hair.
- × Do not handle cuttings by hand because they are very sharp. Do not free a stalled cutter without turning the power off first. Do not clean hands with cutting fluids.
- × Do not use rags or wear gloves near moving parts of machines.
- × Do not use compressed air to blow debris from machines or to clean dirt from clothes.
- × Do not force the machine. It will do the job safer and better at the rate for which it was designed.



BEFORE OPERATING ANY MACHINE, TAKE TIME TO READ AND UNDERSTAND ALL SAFETY SIGNS AND SYMBOLS. IF NOT UNDERSTOOD SEEK EXPLANATION FROM YOUR SUPERVISOR.

2.1 GENERAL METALWORKING MACHINE SAFETY Cont.

HAZARDS ASSOCIATED WITH MACHINES include, but are not limited to:

- Being struck by ejected parts of the machinery
- Being struck by material ejected from the machinery
- Contact or entanglement with the machinery
- Contact or entanglement with any material in motion

Health Hazards (other than physical injury caused by moving parts)

- Chemicals hazards that can irritate, burn, or pass through the skin
- Airborne items that can be inhaled, such as oil mist, metal fumes, solvents, and dust
- Heat, noise, and vibration
- Ionizing or non-ionizing radiation (X-ray, lasers, etc.)
- Biological contamination and waste
- Soft tissue injuries (for example, to the hands, arms, shoulders, back, or neck) resulting from repetitive motion, awkward posture, extended lifting, and pressure grip)

Other Hazards

- Slips and falls from and around machinery during maintenance
- Unstable equipment that is not secured against falling over
- Safe access to/from machines (access, egress)
- Fire or explosion
- Pressure injection injuries from the release of fluids and gases under high pressure
- Electrical Hazards, such as electrocution from faulty or ungrounded electrical components
- Environment in which the machine is used (in a machine shop, or in a work site)



MACHINES ARE SAFEGUARDED TO PROTECT THE OPERATOR FROM INJURY OR DEATH WITH THE PLACEMENT OF GUARDS. MACHINES MUST NOT BE OPERATED WITH THE GUARDS REMOVED OR DAMAGED.

2.2 SPECIFIC SAFETY FOR SHRINKER STRETCHERS

DO NOT use this machine unless you have been instructed in its safe use and operation and have read and understood this manual.



Safety glasses must be worn at all times in work areas.



Close fitting protective clothing or overalls are encouraged



Appropriate protective footwear with substantial uppers must be worn.



Rings and jewelry must NOT be worn in the workshop



Gloves should be worn when handling the work piece



Ear protection should be used in loud and noisy conditions

PRE-OPERATIONAL SAFETY CHECKS

1. Ensure you are familiar with the operation of the Shrinker Stretcher
2. Check for any damage or parts missing
3. The area around the machine must be clean and free of trip hazards.
4. Any forming die must be inspected for safe use i.e. no cracks.
5. Ensure safety glasses or goggles are available and are worn by all persons in the vicinity.
6. Any test piece, project or material (work piece) to be worked must be of an appropriate thickness and safe to use on this equipment.
7. Faulty equipment must not be used. Immediately check suspect machinery.

OPERATIONAL SAFETY CHECKS

1. Place your test piece, project or material (work piece) securely between the top and bottom jaws
2. Do not over reach. Maintain a balanced stance at all times, so that you do not fall or lean against the machine.
3. Use the Shrinker Stretcher pedal, in a pumping action, to slowly work the material.
4. Keep hands and fingers away from jaws.
5. Wear leather gloves when handling the work piece.
6. Use the right tool. Do not force a jaw set to do a job that it was not designed to do.
7. Give your work undivided attention. Looking around, carrying on a conversation and "horseplay" are careless acts that can result in serious injury
8. DO NOT apply excessive force to the Shrinker Stretcher.

AFTER OPERATION COMPLETED

1. After use, clean the machine down and place any tools and equipment in the appropriate storage area.
2. Place all scrap or waste in the appropriate bin.

POTENTIAL HAZARDS

- Beware of high forces applied
- Eye injuries – flying or shattering objects
- Pinch and squash
- Laceration injuries

2.3 LIFTING INSTRUCTIONS

WARNING

This machine is extremely heavy. Serious personal injury may occur if safe moving methods are not followed. To be safe, you will need assistance and power equipment when moving the shipping crate and removing the machine from the crate.



On the day that the machine arrives, make sure that a forklift or lifting device, with sufficient capacity is available to unload the machine from the vehicle. Ensure access to the chosen site is clear and that doors and ceilings are sufficiently high and wide enough to receive the machine.

LIFTING POINT

When lifting the machine only certified lifting web slings should be used. Ensure that when lifting, the machine does not tip over. Check that the lifting slings do not interfere with the parts of the machine that may be damaged. (Fig.2.1)



3. SETUP

3.1 ASSEMBLY

THE METALMASTER Shrinker & Stretcher will require minor assembly prior to operation. It is important that the entire manual is read to become familiar with the unit BEFORE you assemble and use the Machine. Before assembling the Metal Shrinker Stretcher, be sure that you have all parts described in the Parts List. (Fig.3.1)

To assemble the machine:

1. Mount the Bottom Plate(49#) to the Frame (1#) using Screws M8 x 25mm (50#), M8 Washers (51#), M8 Spring Washers (53#), and M8 Nuts (52#).
2. Mount the Bottom Plate(49#) on the floor through the four mounting holes. (See Figure 3.1)
3. Connect the Footplate Bar (2#) into the Frame (1#) using Shaft (17#) and two Screws M10 x 16 (33#). (See Figure 3.1.)
4. Screw the Bar (3#) onto the big M16 x 120mm Bolt (48#) on the Footplate Bar (2#).Screw in about 40mm.
5. Put the Shaft (18#) into the upper hole of the "T" Bolt (54#), then connect the "T" Bolt (54#) and the Driving Wheel (6#) with two Screws M8 x 16mm (36#). (See Figure 3.1)
6. Attach the Frame (1#) and Footplate Bar (2#) using the Spring (24#). (See Figure 1.)
7. Insert the appropriate Shims (42#, 43#, 44#, 45#) between the Jaw Bases (5#) and the Jaw Covers (8#) to make the Jaws(9#,10#,13#,14#) parallel when depressing the jaws together.

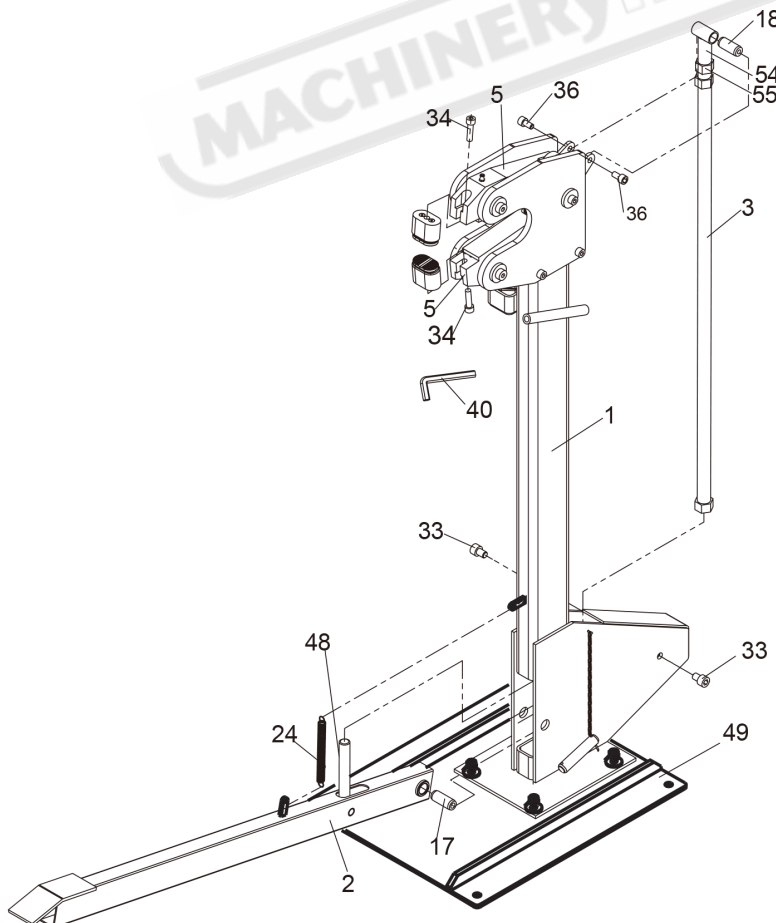

Fig. 3.1

3.2 CLEAN - UP

The unpainted surfaces of the machine have been coated with a waxy oil to protect them from corrosion during shipment. Remove the protective coating with a solvent cleaner or a citrus based degreaser.

Optimum performance from your machine will be achieved when you clean all moving parts or sliding contact surfaces that are coated with rust prevented products.

It is advised to avoid chlorine based solvents, such as acetone or brake parts cleaner, as they will damage painted surfaces and strip metal should they come in contact. Always follow the manufacturer's instructions when using any type of cleaning product.

3.3 SITE PREPARATION

When selecting the site for the machine, consider the largest size of workpiece that will be processed through the machine and provide enough space around the machine for operating the machine safely. Consideration should be given to the installation of auxiliary equipment. Leave enough space around the machine to open or remove doors/covers as required for the maintenance and service as described in this manual.

It is recommended that the machine is anchored to the floor to prevent tipping or shifting. It also reduces vibration that may occur during operation.

OPTIONS FOR MOUNTING

The machine is best mounted on a concrete slab.

Masonry anchors with bolts are the best way to anchor machinery, because the anchors sit flush with the floor surface, making it easy to unbolt and move the machine later, if needed. (Fig. 3.2)

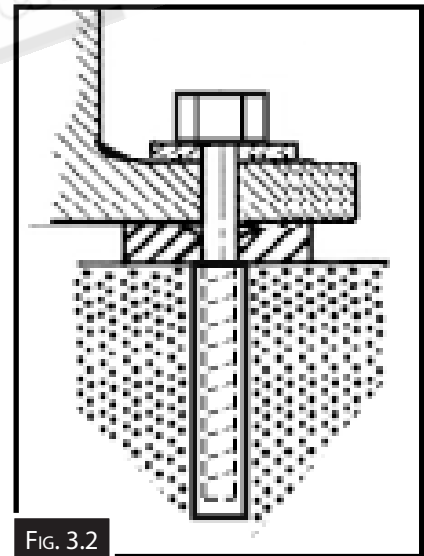

FIG. 3.2

3.4 MACHINE LEVELING

To set your machine up so that it operates to optimum performance, apply the following procedure

After your machine has been anchored to a concrete slab floor, it then needs to be leveled.

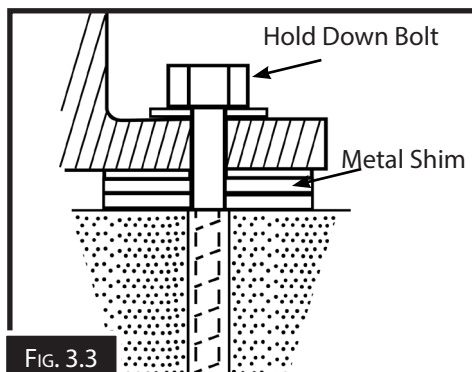

FIG. 3.3

To level the machine:

Loosen the hold down bolts and lightly clamp a piece of straight steel between the jaws and measure each end with a tape measure to the floor. Metal shims need to be placed under corner of the base of the machine until level and the machine is stable with each corner sitting firmly on the floor. Once level then tighten the hold down bolts. (Fig. 3.3).

4. OPERATION

4.1 OPERATION OVERVIEW

The metal shrinker-stretcher basically does exactly what its name implies: shrink or stretch metal. It does this with two sets of jaws. As each one clamps down it either compresses the metal or pulls it apart, which creates the shrinking or stretching action. In this way, the tool actually changes the thickness of the steel, which makes part of the piece longer or shorter depending on which jaw set is used. The dimensions of the un-worked section remains the same, so the lengthened or shortened sections created by the tool cause the metal to deform into a curved shape. It's useful for creating curved corner pieces of sheet metal.

To operate the METALMASTER Shrinker Stretcher:

1. Make a template out of cardboard or a piece of wire, of the outline of the form that needs to be produced. A good fit is essential to reduce the amount of filler that may be required to assemble and finish the project.
2. Select and fit either the shrinking jaws or the stretching jaws.
3. If creating a flanged form, before working the material on a Metalmaster Shrinker Stretcher bend the piece of sheet metal to 90° on a folder. (Maximum flange width is 120mm)
4. Place the material between the upper and lower jaws, and press the foot pedal, working the leading edge first. This will break down the maximum resistance and permits easy and accurate working thereafter.
5. For best results and maximum forming power, insert metal only halfway into the jaws.
6. Bunching or pocketing that typically occurs when shrinking may need to be fixed with some hammering out.
7. Control the pressure exerted on the pedal of Footplate Bar while forming the metal.
8. Move the metal back and forth until the desired radius is obtained.
9. The jaws of the tools are "toothed" to better grip the metal. These teeth leave slight markings, depending on the hardness of the metal, and can be removed with an abrasive cloth or wheel.

CAUTIONARY TIPS

1. Wear gloves to avoid cuts that may come from material handling, during all forming operations
2. To avoid dulling the teeth, NEVER press the jaws together without a separator between them.
3. ALWAYS insert a piece of metal or other material divider between the jaws when not in use.

5. MAINTENANCE

5.1 CLEANING AND OILING

When finished with the machine always clean down the machine and oil with a light oil all moving parts and machined surfaces.

Clean both of the jaws when finished. Using an air gun or vacuum will remove the surface dirt but to clean them properly, disassemble the jaws as follows.

1. Loosen the top and bottom screws (#34), to remove the die assembly. (Fig.5.1)
2. Remove the jaws from the jaw cover (#8) by loosening the two Phillips head screws (#37).

NOTE: Be careful not to loose the spring between the jaws

3. Clean the jaws and V-blocks with cleaning fluid and a brush. Do not use a wire brush or a wire wheel. Always brush in the same direction as the teeth, with the grooves.
4. Reassemble and replace the dies.

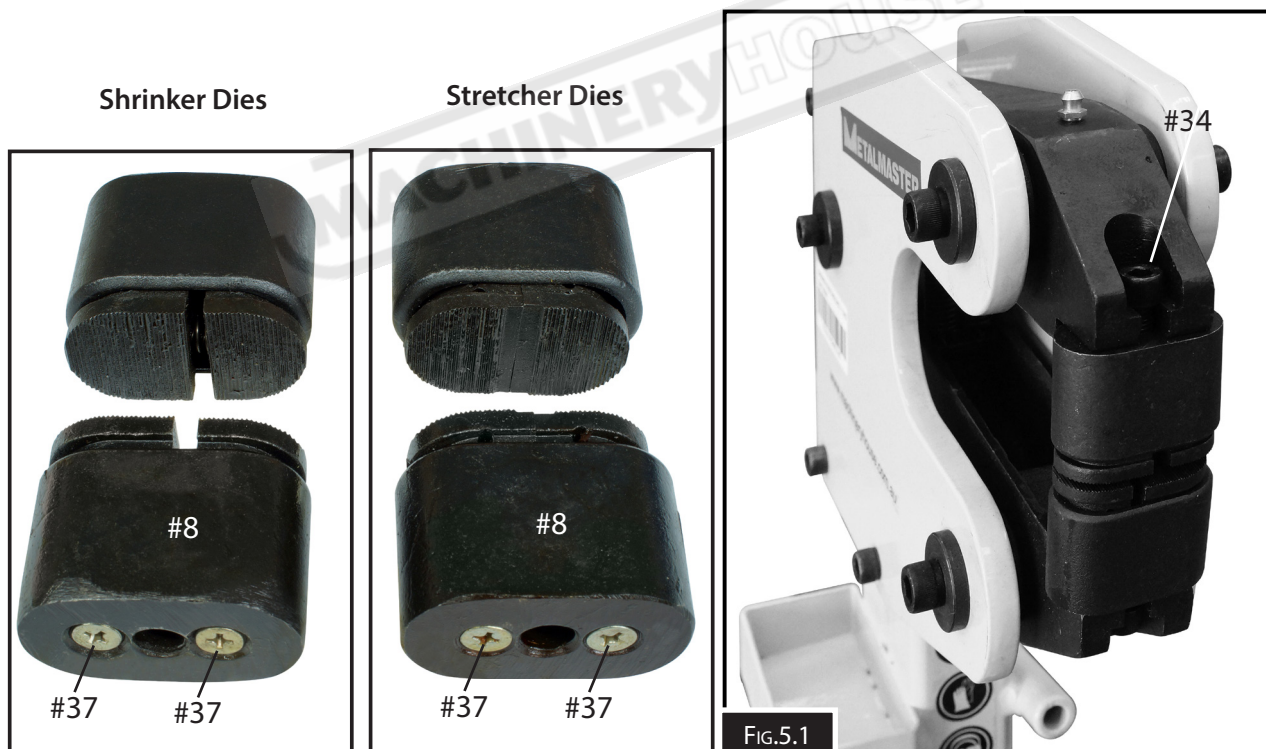

SPARE PARTS SECTION

Shrinker Stretcher

Model. SHST1.2HO

Order Code S2264

Edition No : SHST1.2HO-1

Date of Issue : 02/2021

The following section covers the spare parts diagrams and lists that were current at the time this manual was originally printed. Due to continuous improvements of the machine, changes may be made at any time without notification.

HOW TO ORDER SPARE PARTS

1. Have your machines **model number, serial number & date of manufacture** on hand, these can be found on the specification plate mounted on the machine
2. A scanned copy of your parts list/diagram with required spare part/s identified.

NOTE: SOME PARTS MAY ONLY BE AVAILABLE AS AN ASSEMBLY

3. Go to www.machineryhouse.com.au/contactus and fill out the inquiry form attaching a copy of scanned parts list.

CONTENTS

Spare Parts Diagram.....	16
Spare Parts List.....	17

SPARE PARTS DIAGRAM

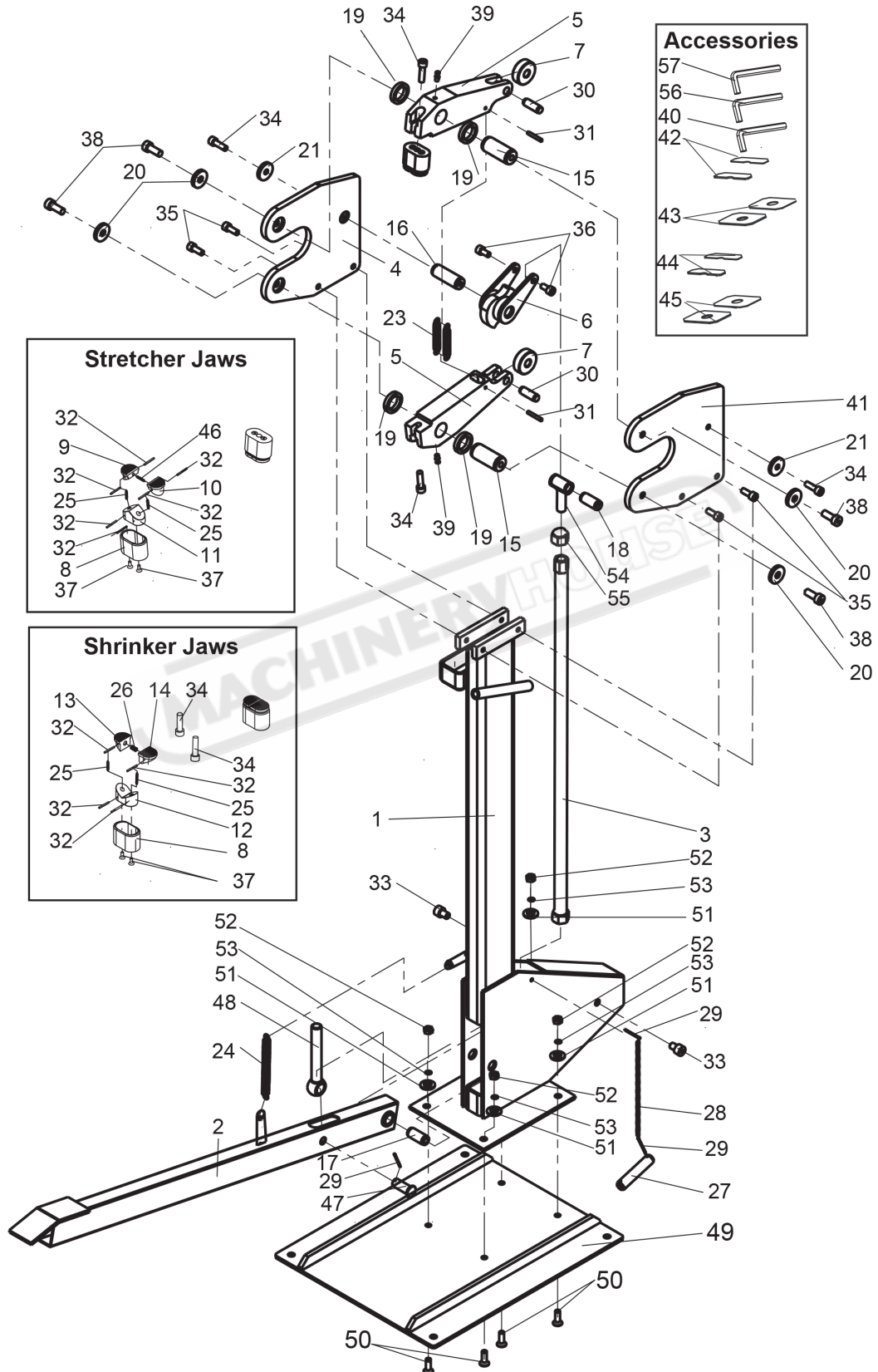

SPARE PARTS LIST

ITEM	DESCRIPTION	QTY.	ITEM	DESCRIPTION	QTY.
1	Frame	1	30	Pin 12mm	2
2	Footplate Bar	1	31	Pin 4mm	2
3	Bar	1	32	Pin 2.5mm	20
4	Left Side Support	1	33	Screw M10×16	2
5	Jaw Base	2	34	Screw M8×20	6
6	Driving Wheel	1	35	Screw M8×25	4
7	Driven Wheel	2	36	Screw M8×16	2
8	Jaw Cover	4	37	Screw M5×10	8
9	Stretcher Jaw 1	2	38	Screw M10×20	4
10	Stretcher Jaw 2	2	39	Lubricating Nipple	2
11	Stretcher V-Block	2	40	Wrench 6mm	1
12	Shrinker V-Block	2	41	Right Side Support	1
13	Shrinker Jaw 1	2	42	0.5mm Half Shim	2
14	Shrinker Jaw 2	2	43	0.5mm Whole Shim	2
15	Shaft 25mm	2	44	1mm Half Shim	2
16	Shaft 20mm	1	45	1mm Whole Shim	2
17	Shaft 16mm	1	46	Spring	2
18	Shaft 16mm	1	47	Pin	1
19	Washer 25mm	4	48	Bolt M16×120	1
20	Washer 10mm	4	49	Bottom Plate	1
21	Washer 8mm	2	50	Screw M8X25	4
23	Spring	2	51	Washer 8mm	4
24	Spring	1	52	Nut M8	4
25	Spring	8	53	Spring Washer 8mm	4
26	Spring	2	54	"T" Bolt	1
27	Pin 16mm	1	55	Nut M16	1
28	Chain	1	56	Wrench 5mm	1
29	Pin 4mm	3	57	Wrench 8mm	1

NOTE: SOME INDIVIDUAL PARTS MAY ONLY BE AVAILABLE AS AN ASSEMBLY

WARNING

General Machinery Safety Instructions

Machinery House
requires you to read this entire Manual before using this machine.

- 1. Read the entire Manual before starting machinery.** Machinery may cause serious injury if not correctly used.
- 2. Always use correct hearing protection when operating machinery.** Machinery noise may cause permanent hearing damage.
- 3. Machinery must never be used when tired, or under the influence of drugs or alcohol.** When running machinery you must be alert at all times.
- 4. Wear correct Clothing.** At all times remove all loose clothing, necklaces, rings, jewelry, etc. Long hair must be contained in a hair net. Non-slip protective footwear must be worn.
- 5. Always wear correct respirators around fumes or dust when operating machinery.** Machinery fumes & dust can cause serious respiratory illness. Dust extractors must be used where applicable.
- 6. Always wear correct safety glasses.** When machining you must use the correct eye protection to prevent injuring your eyes.
- 7. Keep work clean and make sure you have good lighting.** Cluttered and dark shadows may cause accidents.
- 8. Personnel must be properly trained or well supervised when operating machinery.** Make sure you have clear and safe understanding of the machine you are operating.
- 9. Keep children and visitors away.** Make sure children and visitors are at a safe distance for you work area.
- 10. Keep your workshop childproof.** Use padlocks, Turn off master power switches and remove start switch keys.
- 11. Never leave machine unattended.** Turn power off and wait till machine has come to a complete stop before leaving the machine unattended.
- 12. Make a safe working environment.** Do not use machine in a damp, wet area, or where flammable or noxious fumes may exist.
- 13. Disconnect main power before service machine.** Make sure power switch is in the off position before re-connecting.
- 14. Use correct amperage extension cords.** Undersized extension cords overheat and lose power. Replace extension cords if they become damaged.
- 15. Keep machine well maintained.** Keep blades sharp and clean for best and safest performance. Follow instructions when lubricating and changing accessories.
- 16. Keep machine well guarded.** Make sure guards on machine are in place and are all working correctly.
- 17. Do not overreach.** Keep proper footing and balance at all times.
- 18. Secure workpiece.** Use clamps or a vice to hold the workpiece where practical. Keeping the workpiece secure will free up your hand to operate the machine and will protect hand from injury.
- 19. Check machine over before operating.** Check machine for damaged parts, loose bolts, Keys and wrenches left on machine and any other conditions that may effect the machines operation. Repair and replace damaged parts.
- 20. Use recommended accessories.** Refer to instruction manual or ask correct service officer when using accessories. The use of improper accessories may cause the risk of injury.
- 21. Do not force machinery.** Work at the speed and capacity at which the machine or accessory was designed.
- 22. Use correct lifting practice.** Always use the correct lifting methods when using machinery. Incorrect lifting methods can cause serious injury.
- 23. Lock mobile bases.** Make sure any mobile bases are locked before using machine.
- 24. Allergic reactions.** Certain metal shavings and cutting fluids may cause an allergic reaction in people and animals, especially when cutting as the fumes can be inhaled. Make sure you know what type of metal and cutting fluid you will be exposed to and how to avoid contamination.
- 25. Call for help.** If at any time you experience difficulties, stop the machine and call you nearest branch service department for help.

WARNING

Shrinker Stretcher Safety Instructions

Machinery House
requires you to read this entire Manual before using this machine.

- 1. Maintenance.** Make sure all moving parts are locked down before any inspection, adjustment or maintenance is carried out.
- 2. Shrinker Stretcher Condition.** Shrinker Stretcher machine must be maintained for a proper working condition. Never operate a Shrinker Stretcher machine that has damaged or worn parts. Scheduled routine maintenance should be performed on a scheduled basis.
- 3. Hand Hazard.** Keep hands and fingers clear from moving parts. Serious injury can occur if hands or finger tips are placed between moving parts.
- 4. Gloves & Glasses.** Always wear leather gloves and approved safety glasses when using this machine.
- 5. Avoiding Entanglement.** Tie up long hair and use the correct hair nets to avoid any entanglement with the Shrinker Stretcher machine moving parts.
- 6. Understand the machine's controls.** Make sure you understand the use and operation of all controls.
- 7. Work area hazards.** Keep the area around the Shrinker Stretcher machine clean from oil, tools, chips. Pay attention to other persons in the area and know what is going on around the area to ensure unintended accidents.
- 8. Guards.** Do not operate this machine without the correct guards in place. Necessary guards protect you from moving parts.
- 9. Material condition.** Material must be clean from oil and dry. Oily material can slip.
- 10. Material hardness.** Make sure your hardness is the same throughout the material, we recommend that you use certified material. Never use hardened steel, glass or fragile material on this machine.
- 11. Level machine.** Level the machine on a flat concrete surface by using a spirit level and secure with to floor.
- 12. Feeding material.** Shrinking or Stretching a tight radius in one pass is not possible. So you need several passes before you can achieve a certain radius.
- 13. Call for help.** If at any time you experience difficulties, stop the machine and call your nearest branch service department for help.

PLANT SAFETY PROGRAM

NEW MACHINERY HAZARD IDENTIFICATION, ASSESSMENT & CONTROL

Shrinker Stretcher

Developed in Co-operation Between A.W.I.S.A and Australia Chamber of Manufactures
This program is based upon the Safe Work Australia, Code of Practice - Managing Risks of Plant in the Workplace (WHSA 2011 No10)

Item No.	Hazard Identification	Hazard Assessment	Risk Control Strategies (Recommended for Purchase / Buyer / User)
B	CRUSHING	LOW	Secure & support work material. Ensure machine is bolted down.
C	CUTTING, STABBING, PUNCTURING	MEDIUM	Wear gloves to prevent cuts from sharp material.
D	SHEARING	MEDIUM	Keep hands clear from moving parts.

Plant Safety Program to be read in conjunction with manufactures instructions



www.machineryhouse.com.au



www.machineryhouse.co.nz

Authorised and signed by:

Safety officer:

Manager:

Revised Date: 12th March 2012